



MESCON TECHNOLOGIES, INC.

SST-270
Smart Flow Transmitter
USER MANUAL

Document: MAN_SST270.DOC
Revision 1.00
Date: February 15, 2000

INTRODUCTION 3

DESCRIPTION 3

SST270 SMART TRANSMITTER BASICS 4

KEYBOARD DESCRIPTION 4

CONFIGURING THE SST270..... 4

ENTERING NUMERICAL VALUES..... 5

MAIN MENU 5

ERROR MESSAGE UTOF 5

 6

 ISPUNIT 7

 ECPOINT ACTION..... 7

 ET 4 M AND ET 20M 8

 RIM 8

 ILTER 8

 9

 9

GENERAL SPECIFICATIONS 10

PERFORMANCE SPECIFICATIONS..... 11

WIRING DIAGRAMS 12

Magnetic Sensors..... 12

Hall Effect Optoelectric Sensors with Single Power Supply 12

Hall Effect Optoelectric Sensors with Dual Power Supplies 13

SST270 PROGRAMMING FLOWCHART..... 14

INTRODUCTION

This manual has been prepared specifically to assist with the installation and programming of your Smart Transmitter. Mescon transmitters are reliable, easy to install and simple to program. Please read this manual carefully. Call your sales representative of Mescon Technologies if further assistance is needed.

DESCRIPTION

The SST270 is a state of the art microprocessor based smart 2-wire transmitter. It incorporates advanced electronic circuitry, and software that enables it to provide a high degree of performance and system flexibility, yet at reasonable cost and ease of use. In a current loop-
-up providing a simple, robust flow measuring system. Using an external power supply, a Hall effect sensor may be used to provide improved resolution and turndown. The SST270 provides content RATE display in user configured units. Its built in Linearization table allows up to sixteen points for accurate flowmeter performance in a variety of conditions.

® interface allows the unit to communicate Universal HART commands

using the STP200 Programmer, or the optional STK200 built in Display/Programming Key Pad module.

Before attempting to program the SST270, please read and understand this manual and make you acquainted with its keyboard and display.

HART® is a registered trade mark of the hart communication foundation.

SST270 SMART TRANSMITTER BASICS

The Display/Programming Module consists of a 4-button keyboard and an 8-character, single row LCD display. The display is used to indicate the values of the measured

i

KEYBOARD DESCRIPTION

↵ -

« -

program. Also used to interrupt the programming sequence and switch into the

⤴ -

decimal point programming. al point to the right during the

⤵ -

program m
during the decimal point programming.

CONFIGURING THE SST270

The SST270 may be supplied with a factory configuration for the input output and display, as specified by the customer. Use this manual to alter and modify the existing configuration parameters. On-site program changes are performed using the

ecting data. As soon as the

programming parameters.

↵ for several seconds until the
data, press «

↵.

NOTE

If you have entered the MAIN MENU, you may now scroll through it using the ⤴ and ⤵ keys. The MAIN MENU includes the following programming functions:

CALIBRATION

calibration information of the flowmeter.

DISPLAY UNITS

flowrate units displayed.

DECIMAL POINT	the decimal point in the display.
SET 4 mA OUTPUT	output.
SET 20 mA OUTPUT	output.
OUTPUT TRIM	for higher accuracy and better performance.
FILTER	the input signals.
SERVICE	display units and show 3 more display characters.
RUN	normal measurement functions.

ENTERING NUMERICAL VALUES

During programming of the SST270, the user may be requested to enter a numerical value. The << key shifts the display pointer to the left by one position, and the ↗ and ↘ keys increment the value of the position. At each position you can select from the following choices: 0 through 9, a decimal point (.), and a minus sign (-). Numbers are entered with the right most digit of the desired value in the right most position of the display. To get the display pointer back on the right side, press << until the pointer wraps around.

MAIN MENU

This section will describe each of the programming functions of the MAIN MENU in detail. These menus enable the user to configure the SST270 to his or her requirements for all applicable input, display, and output parameters. A programming flowchart is provided on page 14 of this manual to aid in programming. Before you can proceed, you must enter the MAIN MENU as described on the previous page.

ERROR MESSAGE

value is greater than the display can accommodate. This might be caused by changes in either the display units or the K-Factor units selection. For example, if you initially enter a K- message will appear. This is because 10,000 puls/cc equals 10,000,000 puls/liter which has too many digits for the display.

problem:

1. Press ↵ to clear the message and stop whatever programming step you are on. -Factor units, or to the
2. Press ↗ and ↘ to clear the message and the existing value. Then enter a new value.

The SST270 utilizes a linearized K-Factor table to convert the input values (frequency) into rate values. The K-Factor table is entered in the CALIBRATION menu. The format of the K-Factor table is in Frequency (HZ) versus K-Factor (pulses/unit volume).

To program the K-factor display. Press \downarrow to continue. Using the \uparrow and \downarrow keys, scroll through the available K-Factor units and press \downarrow to select the desired units. Included in this sub-option will take you directly back to RUN mode. You may get to this option by scrolling through the menu using \uparrow and \downarrow , or you may press \llcorner at any time.

NOTE: the K-Factor volume units are used to set the default display units in volume/minute.

The available K-Factor units are:

- Pulses per Gallon
- Pulses per Liter
- Pulses per Cubic Centimeter

Once the K-factor is displayed, pressing \downarrow will ask you if you wish to enter data into the K-Factor table. To enter data into the K-Factor table press \downarrow . To exit, and not enter the K-Factor table, press \llcorner .

After choosing to enter data into the K-factor table, the display will be played. This is asking you to enter the number of calibration points. Press \downarrow to continue. Enter the desired number of calibration points (the allowed range is 1 to 16 points) and press \downarrow .

Once the table length is defined the display will prompt you to program the K-Factor table in a point by point repetitive cycle. Each point will be programmed in four steps.

NOTE: smallest value in Point No. 1.

Press \downarrow . When you initially enter this routine, the SST270 automatically assumes you want to enter data for point #1. You can accept this point by pressing \downarrow . You can also change this value and press \downarrow to modify any point in the table.

Press \downarrow , then key in an input frequency values (Hz). Press \downarrow to enter.

NOTE, if you are using a single K-factor

Press \downarrow , then key in the K-Factor value corresponding to the value \downarrow to enter.

NOTE: It is recommended that all K-Factor values be entered at the same resolution (i.e. the same decimal point location).

To continue entering K-Factor data points press \downarrow . This will cycle you back to step 1 above and automatically increment the point #. To exit and return to the MAIN MENU press \llcorner .

This function allows you to set the flowrate units of the display. Included in this sub-menu you directly back to RUN mode. You may get to this option by scrolling through the menu using \wedge and \vee , or you may press \ll at any time.

You can choose from five (5) volumetric units,

- Gallons per Minute
- Gallons per Hour
- Liters per Minute
- Liters per Hour
- Cubic Centimeters per minute

four (4) mass based units,

- Pounds per Minute
- Pounds per Hour
- Kilograms per Minute
- Kilograms per Hour

correct conversion factor.

\downarrow to enter the DISPLAY UNITS function. Using the \wedge and \vee keys, scroll through the options of display units and press \downarrow to select the desired units. If you have chosen volumetric units, you are returned to the MAIN MENU. Any other selection will prompt you further as described next.

gravity of the fluid. Press \downarrow to continue. Key in the specific gravity and press \downarrow when finished. You are then returned to the MAIN MENU.

Key in the number and press \downarrow when finished. You are then returned to the MAIN MENU. volume or mass based units described earlier.

The width of the display is eight (8) characters. Three of those are reserved for the display units. The remaining five (5) are available for displaying the flow rate. The decimal point may be moved into any of the available positions in order to get the right amount of precision needed for the metering application. The decimal positions available are as

The SST270 will round up the last displayed digit. For example, if you are running at 12.76 can be very significant at low flow rates. If you are running at 0.5 GPM, but have the display set to

NOTE: If the flowrate is greater than the display can accommodate. For example, if the flowrate is 500 GPM, but the display cannot show the flowrate and you will get an error displayed.

Included in this sub-menu. You may get to this option by scrolling through the menu using \wedge and \vee , or you may press \ll at any time.

Use the \wedge and \vee keys to shift the decimal point to the left or the right by one position at a time. When satisfied with the selection press \downarrow . You are then returned to the MAIN MENU.

Ranging of the output is done in terms of rate values. The SST270 will linearly range the 4-20mA output between the user defined high and low rate values, and scale the display for the corresponding units. If reverse output is desired (4mA for the high rate and 20mA for the low rate) one merely needs to assign the high rate value to 4 mA and the low rate value to 20 mA. The output will be automatically reversed.

From the MAIN MENU and press \downarrow . Key in the desired value of flow rate and press \downarrow . This will return you to the MAIN MENU.

From the MAIN MENU and press \downarrow . Key in the desired value of flow rate and press \downarrow . This will return you to the MAIN MENU.

Certain applications require trimming of the transmitter to fit a specific transducer/sensor or when the exact output values (bias, sensitivity) are not precisely known or may change in time. Trimming enables the user to achieve higher accuracy and better system performance. The trimming operation is performed by a single scaling factor that adjusts the

NOTE: The maximum value of trim is 1.20, and the minimum value of trim is 0.80. If you enter an invalid number the display will prompt you with the allowable limits.

From the MAIN MENU and pressing \downarrow . Key in the trimming factor you wish to use and press \downarrow . This will then return you to the MAIN MENU.

For fast responding input sensors or in particularly noisy environments it may be desirable to filter out the rapid variables and provide a smooth output. The SST270 filter includes a damping factor and a percent band. The damping factor is the equivalent of a low pass filter with time constant measured in seconds. The greater the damping factor, the longer the time constant and the slower the output response to changes in input. The band is the

percent of range over which the damping applies. This allows a fast response for large changes and high damping for small variations.

Scroll through the ↵. You are then
↵ to continue and key in the damping factor followed by ↵.
The allowable values for damping range between 0.0 and 60.0 (units are in seconds). The
display [%]
99%. Press ↵ to continue and key in the value for the band followed by ↵. This will then
return you to the MAIN MENU.

CAUTION: While it sometimes may be tempting to enter a high number for a damping factor, one should note that the response becomes quite slow for factors above a few seconds. Some iterations might be needed for a satisfactory damping factor to be achieved. Most inputs do not require this function.

UNCTION

The service menu is used by the factory for calibration purposes. There is one option available to users. This option allows the user to turn off the display units and have three
unction by selecting
it from the MAIN MENU and pressing ↵ -code.
Press ↵
number 1, and press ↵

turn the units display back on, you must re-described in an earlier section.

ION

RUN is used to exit the MAIN MENU and continue data collection. After all necessary
↵.

GENERAL SPECIFICATIONS

Inputs	Frequency/Pulse. Hall effect or Magnetic sensor.
Frequency Range:	0.5 to 4500 Hz
Trigger Sensitivity:	30 mV @ 0 2kHz, 100 mV @ 2 4.5kHz (Peak to Peak)
Over Voltage Protection:	± 30 VDC
Minimum Range:	None. Limited only by signal quality.
Digital Resolution:	>17 Bits.
Outputs:	4-20mA isolated analog current loop, standard (24V supply recommended). Optional: Digital communication, HART® Protocol.
Maximum Load:	$R_{max} = (V_{supply} - 12)/20 \text{ mA}$
Display (optional):	8x1 Character LCD indicator for programming and display of input and output parameters and status.
Supply:	12-45 VDC (@ no load). Reverse polarity protected.
Operating Conditions:	-4°F TO 158°F {-20°C TO 70°C}. 0-95% RH, non-condensing.
Storage Temperature:	-67°F TO 257°F {-55°C to +125°C}
Turn-on Time:	Within 4 seconds to to rated response.
Response Time:	Linear Input: 0.5 seconds to 99% of reading (2 updated per second). Linearized Input: <1.0 seconds to 99% of reading (>1 updates per second).
Damping Factor:	Programmable 0.0 to 60.0 seconds.
Long Term Stability:	Better than ±0.01% of span for 6 months.
Isolation:	Input/Output: 800 VDC or peak AC. Terminals to Case: 600 VDC or peak AC
RFI/EMI Immunity:	Tested per SAMA PMC 33.1C from 20 to 1000 MHz & for field strength up to 30 V/m.
Enclosure:	Extruded, anodized Aluminum. Optional NEMA 7 explosion proof housing
Dimensions:	Hockey-diameter explosion-proof enclosures.
Approvals:	CE Mark

PERFORMANCE SPECIFICATIONS

Analog Output Resolution:	0.025% of span ($\pm 4 \mu\text{A}$)
Analog Output Linearity:	$\pm 0.025\%$ of span (for D/A)
Supply Voltage Effect:	$< \pm 0.001\%$ per Volt
Calibration:	Automatic. Unit includes all of the calibration parameters. It lf-test, and auto calibration. No field calibration is required.
Linearization:	Up to 16 point K-Factor Linearization correction.
Magnetically Activated Keys: (Optional)	Magnetic reed switch keys allow the keys to be activated from outside the enclosure using a magnetic wand.

WIRING DIAGRAMS

Magnetic Sensors

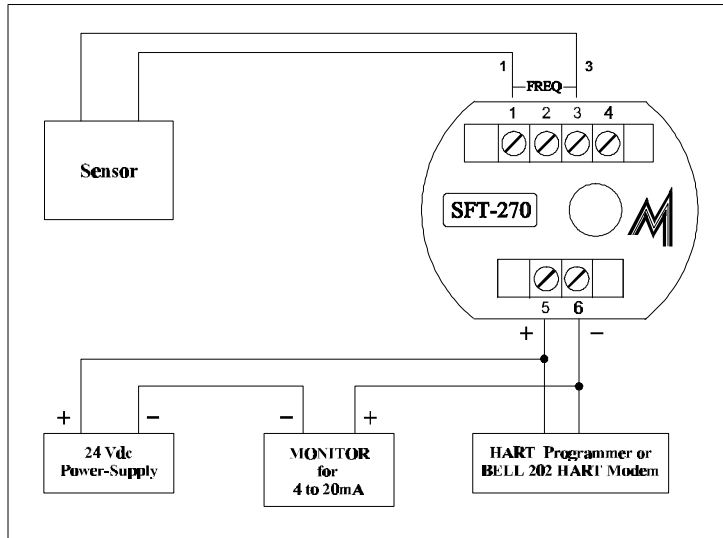

Hall Effect Optoelectric Sensors with Single Power Supply

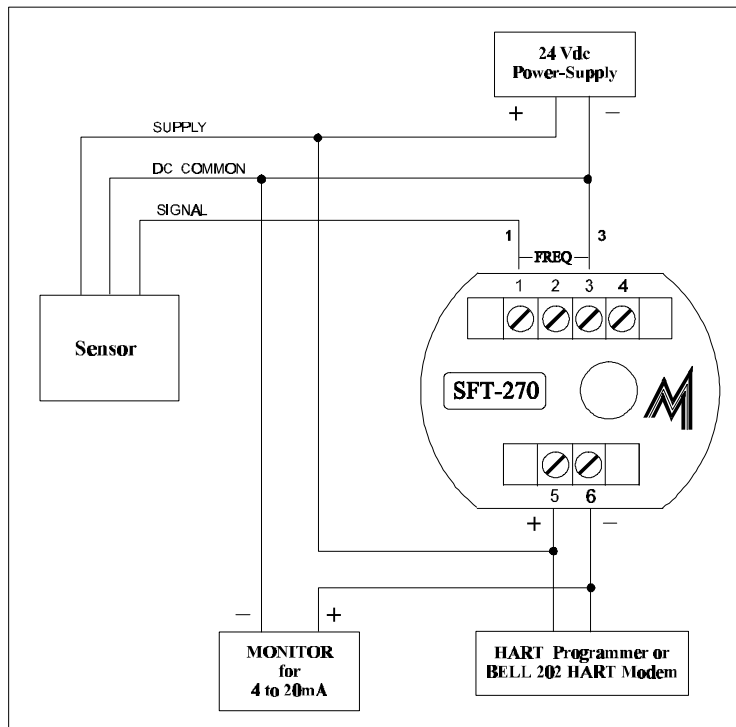

Wiring Note: When the SST270 is not connected to a sensor, its sensitive electronics may pick up ambient electronic noise signals, thus showing a flowrate when there should not be.

Hall Effect Optoelectric Sensors with Dual Power Supplies

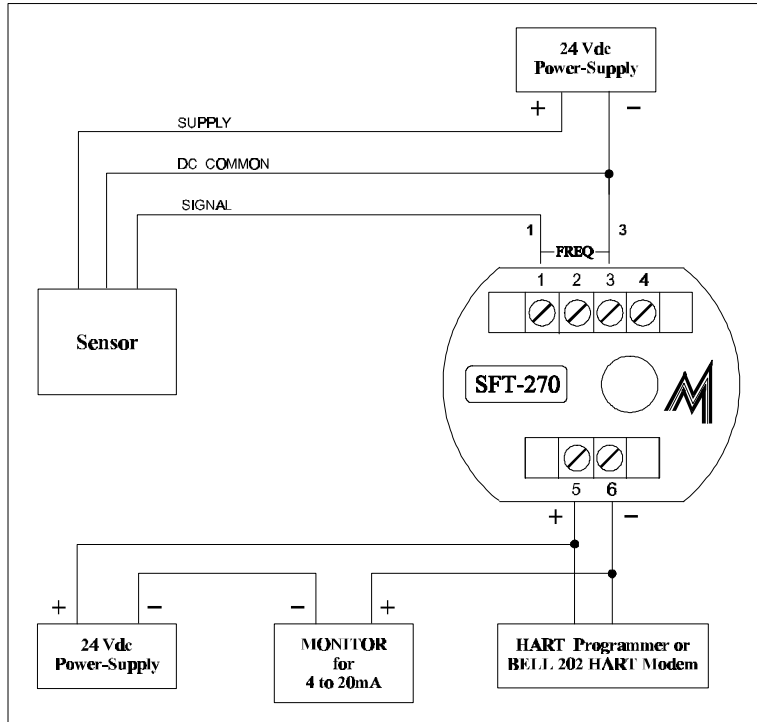

Wiring Note: When the SST270 is not connected to a sensor, its sensitive electronics may pick up ambient electronic noise signals, thus showing a flowrate when there should not be.

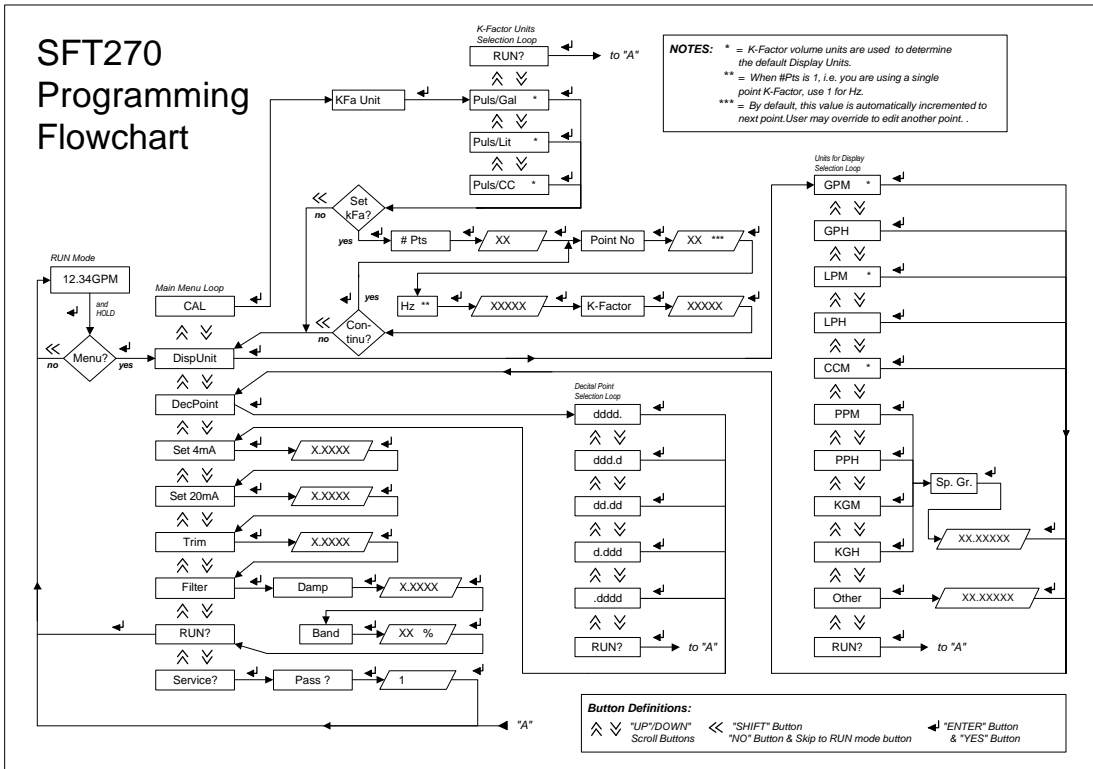

M:\Manual\Drawing\SFT270.vsd (E:\Program files\SFT270.vsd - "VISIO")