

# Series TH-12U

## Isolated Universal 2-Wire Transmitter for Thermocouple, Pt-100 RTD & mV

**Miniature, Thermal-Head mounted.  
1000 VDC Input to Output Isolation.**

The Mescon TH-12U is an isolated, 2-wire temperature and mV transmitter designed to fit in a standard industrial thermal-head. The new design makes the TH-12U the smallest of its kind, while maintaining all of the features Mescon's Universal Temperature Thermal-Head Transmitters, i.e.:

### STANDARD FEATURES:

- **User selectable input type. Accommodates all Thermocouple types, mV and Pt-100 RTD.**
- **Eliminates ground-loop errors.**
- **Improved noise rejection and RFI/EMI immunity.**
- **Universal input capabilities reduce the required inventory levels for both inplant users and distributors.**



### FEATURES:

- **Custom embedded terminals** for physical rigidity and reliability
- **Low profile enclosure design** for easier mounting and wiring
- **Hinged cover for zero & span pots** for application in dirty environments
- **Separated input/output connection** reduces harmful leakage currents

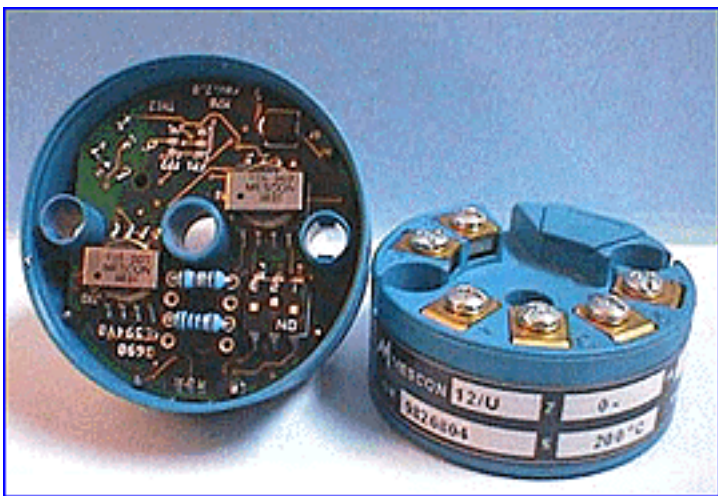

**MESCON**  
Technologies, Inc.

9318 Gulfstream Road, Frankfort, IL 60423 Phone: 815-464-5004 Fax: 815-464-5003  
E-Mail: [mescon@mescontec.com](mailto:mescon@mescontec.com) Web Site: [www.mescontec.com](http://www.mescontec.com)

# Series TH-12U

## Isolated Universal 2-Wire Transmitter for Thermocouple, Pt-100 RTD & mV

### SPECIFICATIONS:

Isolation (I/O):	1000 VDC or peak AC.
Output Span:	4-20mA, limiting @ <28mA
Input:	RTD: Pt-100, 2 or 3 wire TC - all known types.
Input Span:	RTD: 20 °C min. 500 °C max. TC: 5mV min. span.
Adjustability:	±15% for both zero and span.
Burnout Detection:	Upscale - standard.
Supply Voltage:	10-40 VDC polarity protected.
Maximum Load:	$R_{max} = (V_{supply} - 10V)/20mA$
Ambient Temp.:	-20 °C to + 70 °C
Humidity:	0 - 95% RH, Non-condensing
Linearity:	RTD: better than ±0.1% of span referred to sensor temperature. TC/mV: better than ±0.1% of span referred to mV input level.
Stability:	Pt-100 (100 °C span): 0.02% of span/°C TC/mV (25mV input): 0.02% of span/°C
T/C CJC:	< 0.05 °C/°C of ambient temp.

*All specifications are subject to change without notice.*

#### Wiring Instructions:

1. Connect the input signal wires according to the interconnection drawing above.
2. Connect the output signal wires to the digital indicator with a power supply to create an output loop. Observe for proper polarity.

#### Calibration and Adjustment:

1. **Pt-100 RTD:** Connect the Pt-100 sensor simulator to the TH-12 input terminals according to the wiring diagram. Turn the power on.
- T/C:** Connect the Thermocouple sensor simulator to the TH-12 input terminals according to the wiring diagram. Turn the power on. For optimum performance, allow 15 minutes for temperature gradients to equalize.
2. Set the input to the desired minimum signal and adjust the ZERO pot until the current indicator reads 4 mA.
3. Set the input to the desired maximum signal and adjust the SPAN pot until the current indicator reads 4 mA.
4. Repeat steps 2 and 3 until no further adjustment is needed.

Note: If the unit cannot be calibrated to the desired range, it should be returned to the workshop for proper ranging.

#### RTD CONFIGURATION

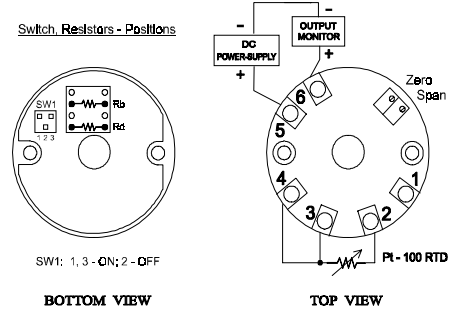

#### THERMOCOUPLE CONFIGURATION

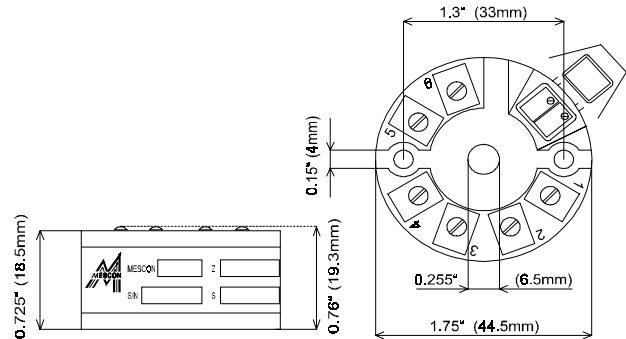
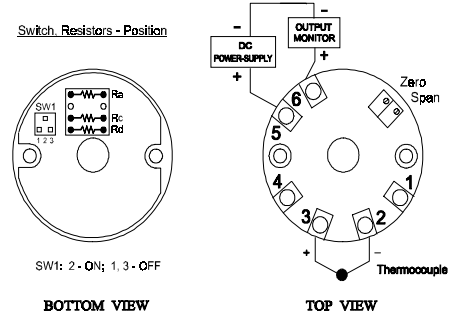

#### Ordering Information:

### TH 12/1 - 3 (0-300) C

Model 12/1 for RTD	12/2 for TC	12/3 for mV
No. of wires for 12/1 TC type for 12/2		
Measurement Range		
Units (°C, °F of mV)		