

AC Amps / Volts Signal Conditioners

Precision, Isolated, Rangeable

Model 40/6, 60/6, (N)

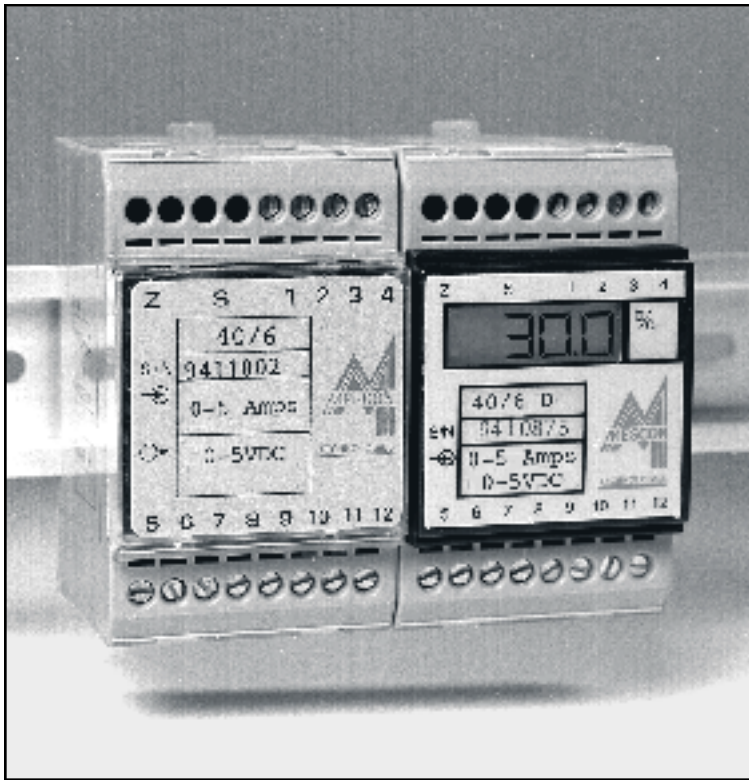

Models 40/6 and 60/6 are precision AC input signal conditioners with full galvanic isolation between the input, the output, and the power supply circuitry. They provide the necessary circuitry for amplification, rectification and processing of current or voltage signals from various AC sensors and signal sources. An optional LCD indicator is available for some models for local indication of the output in engineering units.

The 40/6 and 60/6 can be easily ranged without requiring special tools or board modifications. Models 40/6N and 60/6N are special versions intended to be used for very low currents and low voltages as well as higher voltage measurements over frequencies of up to 2KHz. The /6N versions also provide a full range of output capabilities including all current or voltage standards.

For a 4-20mA output, a test terminal provides a 40-200mV signal which is proportional to the 4-20mA output. This signal is used for monitoring and verification of the output without interrupting or disconnecting the current loop.

FEATURES:

- 4-wire signal conditioners
Series 40 - DC Power Supply
Series 60 - AC Power Supply
- Input/Output/Supply Isolation
- User rangeable input
- Over 2000 Volts Isolation
- Wide ranging ZERO and SPAN
- DIN rail mounting

AVAILABLE OPTIONS:

- 3-1/2 digit backlit LCD indicator
- Higher Current/Voltage ratings
- NEMA 4X or NEMA 7 enclosure



MESCON
Technologies, Inc.

9318 Gulfstream Road, Suite A, Frankfort, IL 60423
Phone: 815-464-5004
Fax: 815-464-5003
E-Mail: mescon@mescontec.com
Web: www.mescontec.com

AC Amps / Volts Signal Conditioners

Precision, Isolated, Rangeable

Model 40/6, 60/6, (N)

SPECIFICATIONS:

Input Range (/6*, 50-60Hz)	Current: 250mA min., 5A max. (up to 12A, optional) Voltage: 30V min., 300V max.
Input Range (/6N**)	Current: 10µA min., 250mA max. Voltage: 100mV min., 500V max. (up to 1000V, optional)
Zero Suppression	To >50% of full range
Output	/6: 4-20mA, limiting at <28mA /6N: Voltage: 0-1, 0-2, 0-5, 0-10V, ±5V, ±10V std. Current: 4-20mA, 0-20mA, 0-1mA, 1-5mA std.
Supply Voltage	40/: 24VDC ±20%, polarity protected 60/: 115 or 230 VAC ±10%, 50/60 Hz 2W max.
Input Voltage Drop	/6: <50mV for 5 Amp input
Input Impedance	/6N: >1M
Input/Output Isolation	/6: 2000 VDC or peak AC /6N: 1000 VDC or peak AC
Linearity (BSLF)	/6: ±0.25% of span max. /6N: ±0.15% of span max.
Conversion Method	AC averaging
Temperature Stability	±0.02% of span/°F
Operating Temperature	-20°C to 70°C, (0°F to 160°F)
Mounting	DIN rail (35mm) or panel (with adapter)
Humidity	0-95%RH, non-condensing

* /6 suffix indicates specifications common to both 40/6 and 60/6.
** /6N suffix refers to the 40/6N and/or 60/6N version.

All specifications are subject to change without notice.

ORDERING INFORMATION

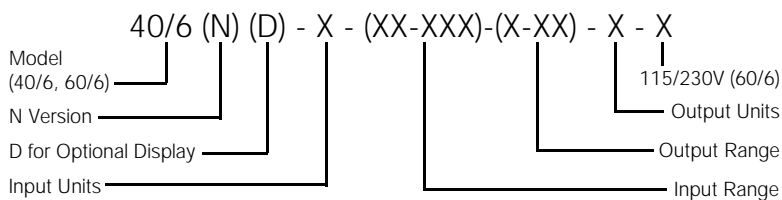

Please request our ordering and calibration diskette describing the rest of Mescon's product.

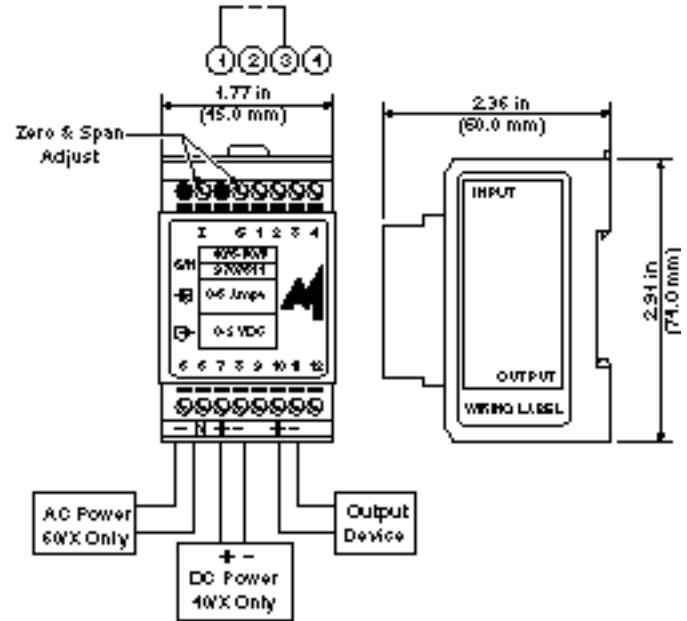

Wiring Instructions:

1. Connect the sensor/input leads according to the diagram above.
2. Connect the output leads to terminals 10 (+) and 11 (-).
3. 40/6 only - connect the DC power supply leads to terminals 7 & 8.
4. 60/6 only - connect the AC supply leads to terminals 5 & 6.

Calibration and Adjustments:

It is assumed that the unit undergoing calibration has been properly ranged at the factory or workshop.

1. Connect an AC voltage or current simulator to the input terminals.
2. Connect the power supply to the power terminals (see diagram). Observe for proper polarity.
3. Connect the input terminals to a precision digital indicator. Turn the power supply on. **For optimum performance, allow 15 minutes of warm-up time.**
4. Set the input for the desired minimum signal. Adjust the ZERO pot for the specific output low end.
5. Set the input for the desired maximum signal. Adjust the SPAN pot for the specific output high end.
7. Repeat steps 4 and 5 until no further adjustment is needed for the desired accuracy.

Note: If the unit cannot be calibrated for the specified range, it should be returned to the workshop for proper ranging.



MESCON
Technologies, Inc.
9318 Gulfstream Road, Suite A, Frankfort, IL 60423
Phone: 815-464-5004
Fax: 815-464-5003
E-Mail: mescon@mescontec.com
Web: www.mescontec.com

Distributed By: